

Product Installation Guide



Wireless Window / Door Sensor Mx-MRC1



Description:

The Magnum Door/Window Sensor helps to provide energy savings for an area by detecting when a door, window or balcony door opens or closes. This device is both wireless and battery-free, functioning instead by harvesting outdoor and in room light through solar cells that power the device. This device can be linked with occupancy sensors to more accurately track when a room is occupied or vacant. This sensor is easy to install on doors or window frames, and virtually anything indoors that opens and closes.

Dimensional Line Drawing:

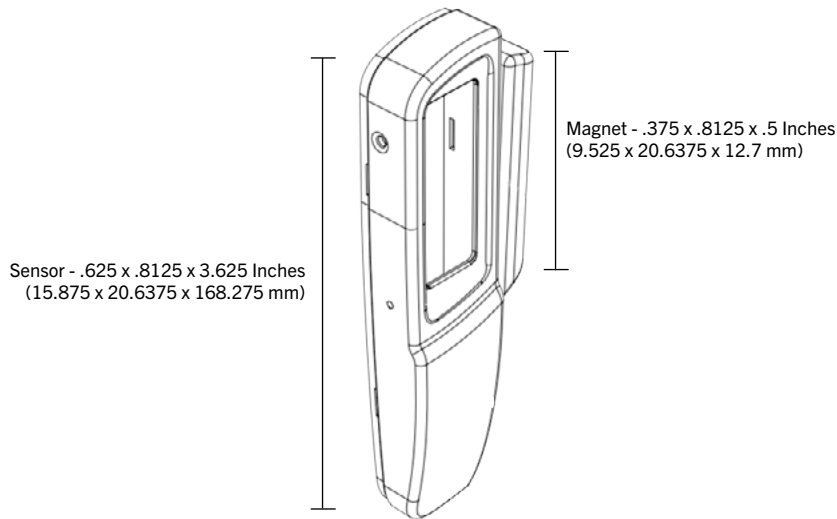

Features Include:

- Sends wireless messages to other devices whenever a door or window opens or closes
- Harvests ambient solar energy to power the sensor and send wireless communication
- Mounts easily on standard doors or windows
- Supplementary battery option for extreme low light conditions

Equipment Needed for Installation:

- Sensor and magnet
- 4 Screws or double sided tape
- Screwdriver
- Leveling tool
- Light meter
- Drill

Planning for Installation:

- Take a moment to prepare for installation and ensure optimal communications with other system components in the space.
- Remove the sensor from its packaging and place it under a strong light to charge for its installation
 - Ensure the location provides consistent and adequate light. This can be in room light and/or natural light exposure.
 - Install according to the alignment requirements
- Consider any materials or obstacles that may interfere with RF signals, such as metal and concrete.

Alignment Requirements:

The proximity of the magnet to the sensor is important for proper detection. The alignment arrows on the sensor and the magnet must point to each other and the gap between them must not exceed .25 inch (6.4mm) in any direction.

Product Installation Guide



Installation:

1. Based on your project requirements, decide where you want to install the sensor and the magnet.
2. For door installations, locate the sensor.
 - a. On the knob side of the door jam, away from the hinges
 - b. Place the sensor at least 1 foot (30cm) above the floor to avoid damage. The higher the better, in most scenarios to avoid tampering by occupants or hotel guests.
3. For window installations, locate the sensor.
 - a. Make sure the location does not expose the sensor to contact with water.
 - b. Don't place the sensor on the outside of a window or balcony door, for instance.
4. Install the sensor on the interior side of the fixed frame.
 - a. Remove the mounting bracket from the sensor
 - b. Position the mounting bracket and mark the two mounting screw drill points
 - c. Insert the first screw loosely and level the mounting bracket.
 - d. Install the second screw, and then hand tighten the first screw.
 - e. Snap the sensor onto the mounting bracket where the notches are located.
 - f. Slide the sensor on the bracket until it snaps into place on the tab lock
5. Install the magnet on the moving part of the door or window.
 - a. Use a screwdriver to press the tab lock and flex the magnet cover to remove it.
 - b. Position the magnet with the proper spacing and alignment, and then install it with the provided screws.
 - c. Replace the magnet cover and snap it into place on the tab lock.

NOTE: For low activity/traffic applications, the magnet can also be mounted with double-sided tape (NOT INCLUDED)

6. Check the alignment arrows and the distance between the sensor and magnet when the door or window is closed.

TIP: There is a faintly audible "click" when the sensor and magnet close and open.

Installing Supplemental Battery (Optional)

If the sensor is installed where there are light levels that are inconsistent or too low, or where there are days of darkness, battery power can be used to supplement the solar energy harvested. Only use a CR1216 battery.

1. Press the tab lock to release the sensor from the mounting bracket.
2. Slide the sensor about ½ inch (1 cm) and remove it from the mounting plate.
3. Insert the battery with the positive pole (+) up and slide it between the two contact terminals with your finger.

WARNING: Ensure the battery is properly oriented. Improper handling of lithium batteries can result in heat generation, explosion or fire.

4. Replace the sensor on the mounting plate and slide it until it snaps into place.
5. Open and close the contact to test for power.
6. There should be a faintly audible "click" and a quick LED blink.

Troubleshooting:

- If the sensor does not generate a wireless message:
 - Verify that there is the faint, but audible "click" when the contact is closed and opened
 - Verify the LED blinks once when the contact is closed and opened
 - Verify that the solar cell is charged properly
 - Check that the magnet is oriented to the sensor properly
 - Check that the alignment arrows are not spaced more than .25 inches apart.

Technical Specifications:

Part Numbers (Frequency Dependant)	M9-MRC1 (902 MHz - North America) M8-MRC1 (868 MHz - Europe and China) MJ-MRC1 (928 MHz - Japan)
Range	75 feet (typical)
Power Supply	Integrated Solar Cell / Super Cap
EEP	D5-00-01
Start up time with empty energy storage, typical	<2.5 min @ 400 lux, 25°C
Initial operation time in darkness, typical	6 days if energy storage is fully charged
Dimensions	Sensor - .625 x .8125 x 3.625 Inches (15.875 x 20.6375 x 168.275 mm) Magnet - .375 x .8125 x .5 Inches (9.525 x 20.6375 x 12.7 mm)
Operating Temperature	-20° up to +60°C
Mounting	Double-sided tape
Ratings and Approvals	FCC (United States) SZV-STM310C I.C. (Canada) 5713A-STM310C