



ALL NEW INTELLIGENT WATER FLOW VALVE

PREVENTS LEAKS. EASY INSTALL. SELF-POWERED. **SAVE BIG!**

ROI & Helping the World WIN!

The all new valve prevents leaks in tank-filled toilets, saving you money, and helping stop the waste of water! In the U.S. alone, we waste over 1 TRILLION gallons of water per year. With nearly 30% of the water flowing into your space going down the toilet, there's a lot of water that can be saved. This not only saves you money based on the water coming in, but also the sewage tax coming out! Throw in a Tiered pricing structure from your utility company, and it becomes pretty clear how one can save 10-20% on their water bill!

These savings grow the longer you have Our valves installed in your space. A leaking toilet can waste about 200 gallons every day, and due to sediment buildup, material degradation, leaks are bound to occur during the lifetime of a toilet. Don't wait to protect your wallet.

Powered by H2O (seriously)

The technical term is energy harvesting. Simply put, we took an age old concept, the water wheel, miniaturized it, and integrated it into our new valves. This generates energy, keeping the valve powered. No replacing batteries, no hard wiring required, simply tie it into your flow of water, and you're all set.

THE ALL NEW INTELLIGENT WATER VALVE



Simple to Use

The motion sensor detects when a user is present, and allows water to flow to the toilet.
No person = No water flow (aka no waste)

Easy to Install

Our product can be installed in minutes, providing an easy transition to saving water!

Take a Look Inside

Solenoid
Valve

Motion
Sensor

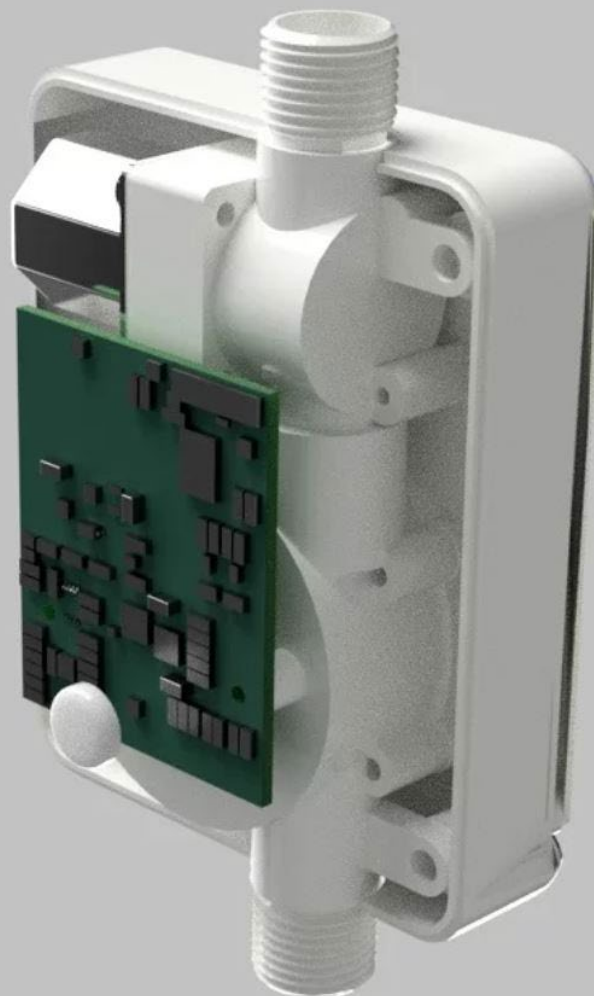

Hydrogenerator

THE ALL NEW INTELLIGENT WATER VALVE



Technical Data

Part Numbers	M-IWV
Operating Temperature	32° - 104°F (0° - 40°C)
Minimum Operating Water Pressure	3 PSI (0.02 MPa)
Thread	1/4 NPT (both sides)
Motion Sensing	Digital Passive IR
Detection Distance	2m (6.56 ft)

Dimensional Drawings

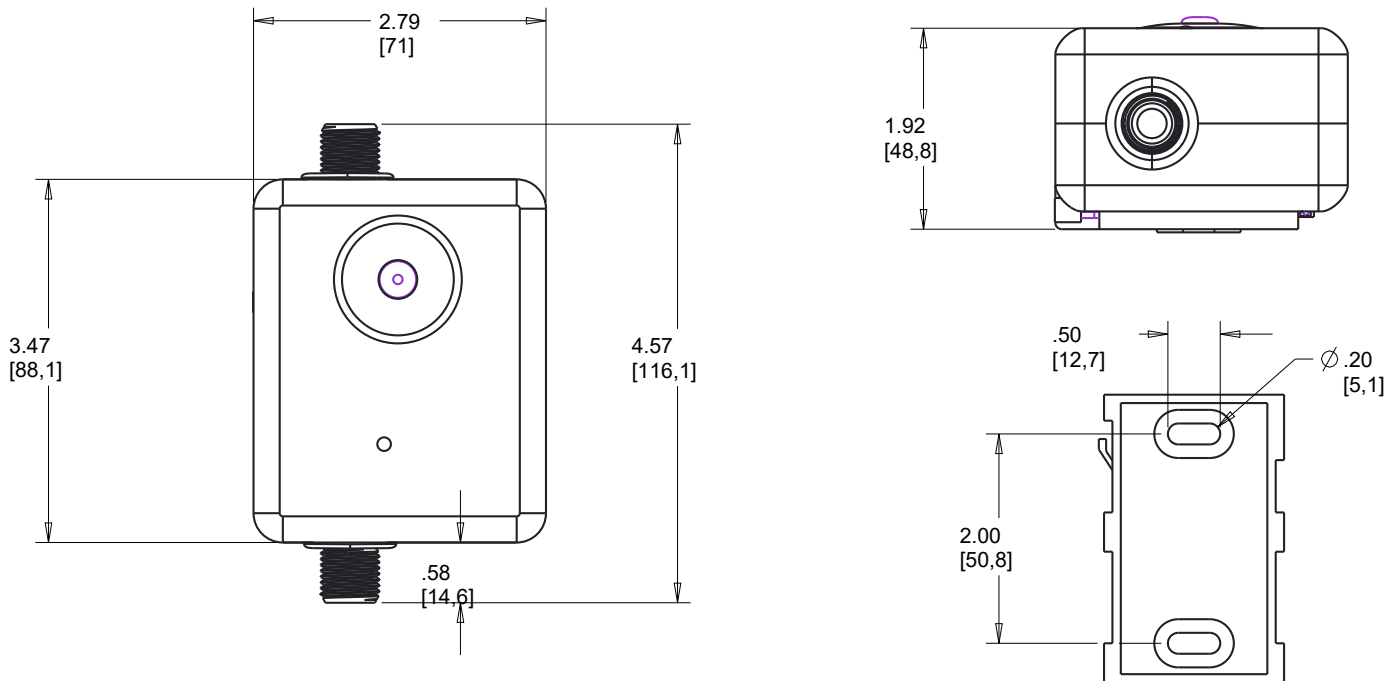

THE ALL NEW INTELLIGENT WATER VALVE



Installation Instructions

Step 1:
Turn Water OFF.



Step 2:
Drain Tank and
remove existing water
line.

*Loosen by hand or use
adjustable wrench
(5/8" wrench)*

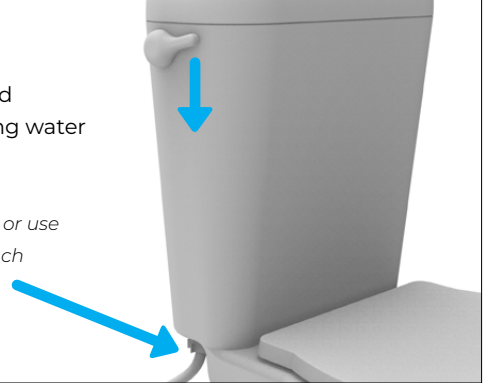

Step 3:
Mount back plate to
wall with the screws
provided.

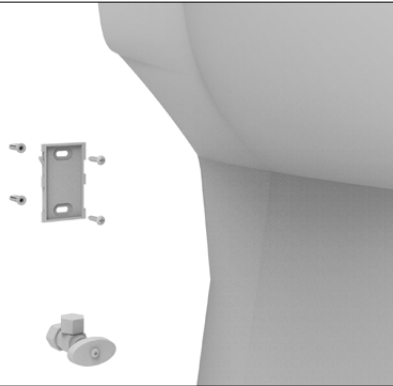

Step 4:
Once mounted, attach
device to the back
plate.

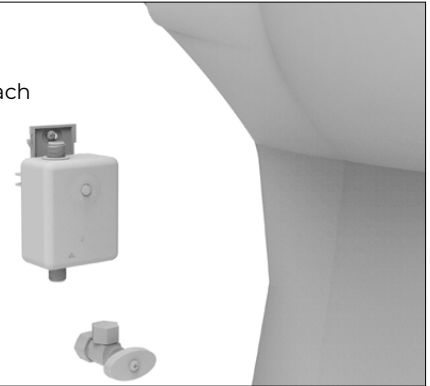

Step 5:
Re-attach water lines
to the device and
toilet.

*NOTE: Water lines
not provided*

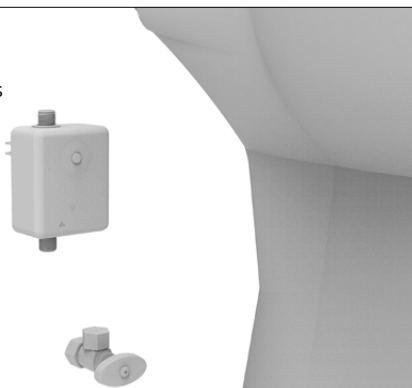

**Your Installation
is Complete!**

