



NOVEMBER 19, 2018 10:47 AM



M9-OPUS-10V12

IN FIXTURE 0-10V LIGHTING CONTROL FOR DIM-TO-OFF DRIVERS (1 CHANNEL)

OVERVIEW:

Magnum's in fixture Mx-OPUS-10V12 is compatible with 0-10V, dim-to-off LED drivers. The Mx-OPUS-10V12 is powered through available low voltage from the driver or an available 12-15VDC source near the fixture level. The Mx-OPUS-10V12 allows for 0-10V dimming and dim-to-off functionality, with compatible LED drivers, providing continuous dimming control to conserve energy, simplify maintenance and personalize the lighting environment.

DESCRIPTION:

The Mx-OPUS-10V12 is integrated into the lighting network at the fixture level. The Mx-OPUS-10V12 gives lighting OEMs and driver manufacturers the flexibility to incorporate lighting control as a value added part of their lighting related offering. The Mx-OPUS-10V12 also allows for multiple drivers to be connected together through the 0-10V output.

The Mx-OPUS-10V12 is designed to mount onto a fixture prior to leaving the manufacturing facility or can be retrofitted after the fact. This node communicates wirelessly over radio frequency to compatible wireless end devices, including occupancy sensors, LUX sensors, light switches and more. The Mx-OPUS-10V12 provides for both localized control as well as software driven functionality using Magnum's VenergyUI software (Mx-AP2). Using Magnum's Mx-EBOX, customers can also integrate the Mx-OPUS-10V12 into an existing BACnet based building automation system (BAS).

OPTIONS IN OPERATION:

Local Control: An on board microprocessor and memory allows for standardized operation at the fixture level, eliminating the reliance on software or network configuration. Mx-OPUS-10V12 can be utilized out of the box with default settings, or configured for advanced operation through AirConfig (https://www.dropbox.com/s/mor2z812401nhti/airConfig_Setup.exe?dl=0). Advanced preferences and behavior settings can be accomplished using simple drag and drop remote configuration in a localized fashion, even after the installation is completed.

Software Driven: The Mx-OPUS-10V12 can also be used with Magnum's VenergyUI software, allowing users to control lighting with their mobile devices.

Integration to BAS: The Mx-OPUS-10V12 has the ability to communicate information through Magnum's eBox (Mx-EBOX) and into an existing building automation system (BAS). The convergence of lighting and building automation allows for granular information to be communicated to the BAS for improved operational efficiency.

FEATURES:

- Wireless communication
- In fixture installation
- Powered from driver or any available 12-15 VDC source
- Compatible with 0-10V, dim-to-off LED drivers
- Remotely configurable

M9-OPUS-10V12

IN FIXTURE 0-10V LIGHTING CONTROL FOR DIM-TO-OFF DRIVERS (1 CHANNEL)

TECHNICAL DATA:

Part Numbers (Frequency Dependent)	M9-OPUS-10V12 (902 MHz - North America) M8-OPUS-10V12 (868 MHz - Europe and China) MJ-OPUS-10V12 (928 MHz - Japan)
Input Voltage	12 to 15 VDC
Dimmer Output	0-10VDC @ 30mA (sinking driver) 5mA (sourcing driver)
Standby Power	< 1W
Number of Outputs	1
Wireless Protocol	EnOcean Wireless Protocol
Operating Temperature	32° - 140°F (0° - 60°C) - Indoor use only
EnOcean Profile	A5-38-08 Type 0x02 Dimming
Wireless Range	150 ft (50 ft-150 ft typical) / 45.72 m (15.24 m - 45.72 m)
Certifications	FCC (United States) SZV-TCM3XXX IC (Canada) 5713A-TCMXXX CE
Dimensions	W: 2.39" (60.71 mm) x H: 0.61" (15.49 mm) D: 1.26" (32.004 mm)

DIMENSIONS:

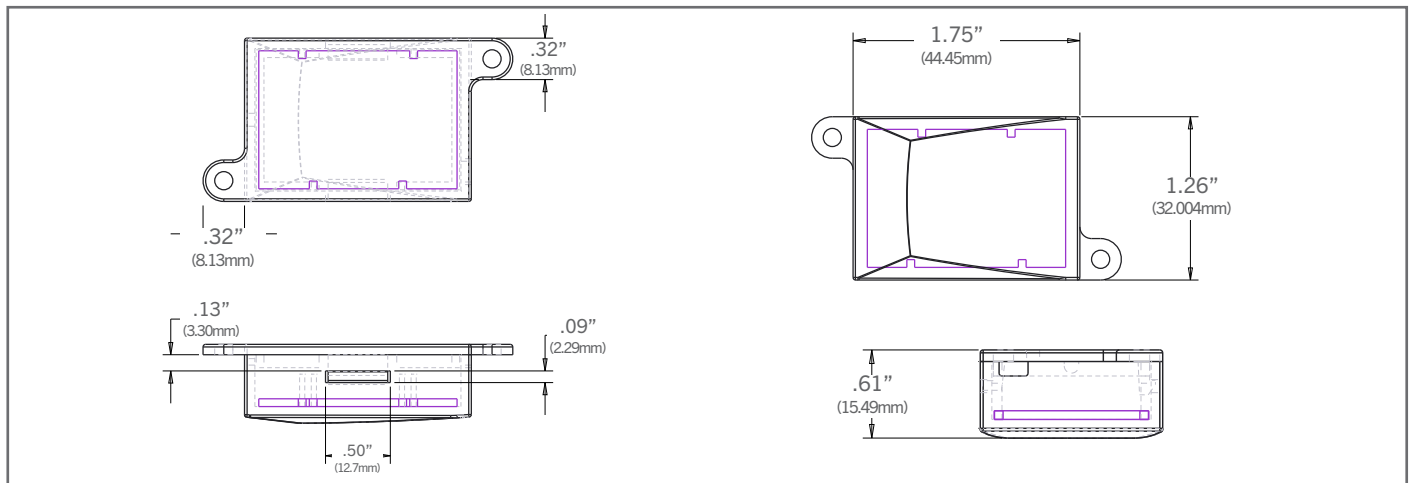

PIGTAIL WIRING DIAGRAM & ANTENNA NOTE:

