

# Integrated Wireless Light Switch

[M9-ILS2]



Proudly Made  
In America

## Description

The Magnum Energy line of Wall Switch Receivers work in conjunction with EnOcean-enabled Self-Powered Wireless Lighting Control Products to provide an optimal solution for the retrofit lighting needs. These wireless products combine Magnum's switching technology with self-powered and wireless technologies, developed and licensed from EnOcean. The Wall Switch Receiver can be installed in place of traditional single-pole wall switches and fits in a standard single-gang wall box. No Additional wiring is required.

These components are compatible with incandescent, fluorescent, and low-voltage lighting. The EnOcean Receiver responds to signals from the EnOcean transmitters switching the relay (controlling the load) on or off. The Receiver features a single push ON/OFF (return-to-neutral) manual-override switch that can be used to toggle the ON/OFF status of the light load.



- RF Wall Switch Receiver fits in a standard single-gang wall box.
- No new wires required, product utilizes existing A/C and Load Wiring.
- Compatible with incandescent, fluorescent and low-voltage lighting.
- Simple, fast installation, replace existing light switch and pair/learn a self powered transmitter switch or sensor in under 10 minutes.
- Decorator style wall switch utilizes the ON/OFF return-to-neutral design.
- Neutral and non-neutral Wall Switch Receiver models are available.



# Integrated Wireless Light Switch

## [M9-ILS2]

### Product Data

#### Applications

Magnum's line of wireless products are the ideal solution for energy saving and efficient lighting retrofits and new construction. Installation is quick and easy with no additional wiring required. Simply replace the existing wall switch with Magnum's Wall Switch Receiver, pair it with a selected Self-Powered Remote Switch or RF PIR Occupancy Sensor and the installation is complete.

The Basic RF Receiver Switch is used for single load applications with Mx-ML2. The Advanced RF Receiver Switch is used for multiple loads when flexibility is desired in design for all Transmitters – Rocker, Momentary and Toggle.

#### Product Compatibility

- Basic: Mx-ML2
- Advanced: EnOcean-enabled Transmitter Switches and Occupancy Sensors -

- Retrofits
- Conference rooms
- Lounges
- Executive offices
- Daycare facilities
- Three-way switch application
- Bi-level lighting or A/B switching.
- New construction
- Classrooms
- Private offices
- Restrooms
- Multimedia areas

### Features

- No New Wiring Required: the RF Wall Switch Receiver simply replaces the existing light switch and then communicates with self-powered switches and sensors via radio frequency.
- Manual ON/OFF Switching: provides pushbutton manual-ON/OFF light switching of each light load at any time.
- Maximize Energy Savings: when paired with RF PIR Occupancy Sensor, RF Wall Switch contains all sensor settings. Manual-ON/Auto-ON, Auto-ON/ Auto-OFF, Walk Through Timer, Auto Time-Out selections of 2 minutes for testing, 10, 20 or 30 minutes. Allows flexibility and customized adjustments to maximize energy savings.
- Presentation/Viewing Mode: turn lights OFF and keep them OFF while room is occupied (i.e.: for slide or film presentations) automatically returns to normal when manually switched back ON or room becomes vacant and time delay expires.
- Walk-Thru Feature: maximizes energy savings by assuring a 2.5 minute time-out if motion is not present after 2 minutes in Auto-ON mode.
- Standard Size for Seamless Installation: RF Wall Switch Receiver fits in a standard single gang wall box. Neutral and non-neutral models available.
- TrueZero-Cross Relay: switches at the zero-crossing point of the AC power curve to ensure maximum contactor life and compatibility with electronic ballasts.
- All Digital Circuitry: uses minimum components for maximum reliability and low cost.
- Energy Savings and Efficiency: lowest power consumption of any RF device - less than 1/2W per 120V device and less than 3/4W per 277V device annually - approximately 70% savings over other RF devices.
- Air Gap Switch: assures A/C power disconnects for safety.
- Color Change Kits: (white, ivory and light almond) included for design flexibility, ease of ordering, inventory and cost control.
- 10A load rating: for commercial lighting circuits.
- EnOcean technology enabled for RF communication from Self-Powered Lighting Controls. Advanced version is compatible with other EnOcean-enabled Transmitter Switches and Occupancy Sensors.
- H.I.S (High In-Rush Stability): arching design for use with all commercial ballasts.
- Retrofit Energy Saving Bi-level Lighting with Occupancy Sensor Control: replace two light switches with RF Wall Switch Receivers, pair both with Self-Powered RF PIR Sensor, set the first RF Wall switch as Auto-ON and the Second as Auto-OFF.

# Integrated Wireless Light Switch

## [M9-ILS2]

### DIMENSIONS

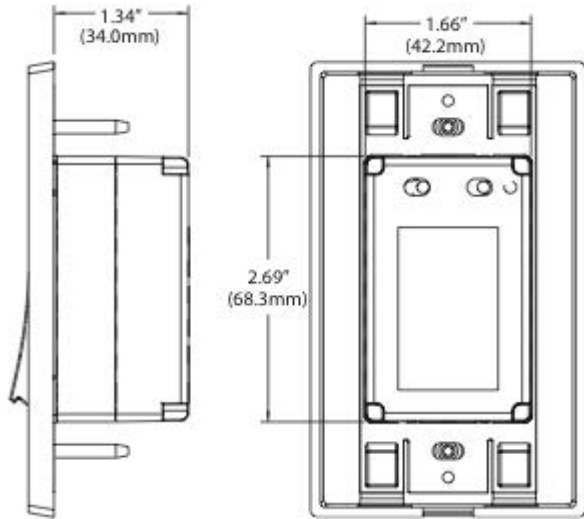

### TECHNICAL SPECIFICATIONS

Part Numbers (Frequency Dependant)	M9-ILS2 (902 MHz - North America) M8-ILS2 (868 MHz - Europe and China) MJ-ILS2 (928 MHz - Japan)
Input Voltage	120-230-277VAC
Operational Frequency	50/60Hz
Power Consumption	120V < 1/2 Watt 277V < 3/4 Watt
Memory	Stores up to 10 Transmitter IDs
Range	50-150 feet (no neutral loses 25')
Button Pairing Modes	Basic / Advanced
Vacancy Confirmation	30 seconds
Load Rating	Incandescent: 800W @ 120V Fluorescent Ballasts: 1200VA @ 120V, 2700VA @ 277V Motor: 1/4 HP Load @ 120V For non-neutral models: 25W minimum load required
Wire Designation	Line-Black, Load-Blue, Neutral-White (Neutral Required models only)
Operating Temperature Range	32°F to 104°F (0°C to 40°C)
Storage Temperature Range	32°F to 104°F (0°C to 40°C)
Relative Humidity	0% to 95% non-condensing
Usage	Indoors Only
Listings	CEC Title 24 compliant C-ETL/ETL Listed to UL508 FCC Certified for wireless communication
Warranty	Limited 5-year

### WIRING DIAGRAMS

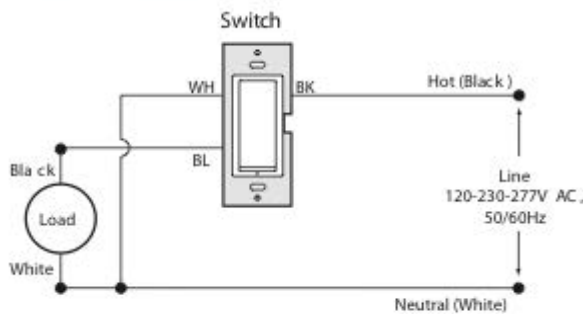

MWSS10 (With Neutral)  
Mx-ILS2 (With Neutral)

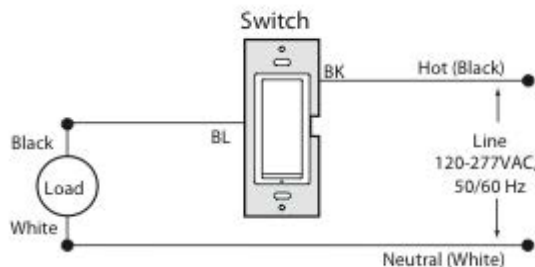

MWSS10-G (No Neutral)

\*All Mx-ILS2 models ship with the Color Change Kit - includes a white, ivory, and light almond faceplate.