

# M9-TS1

24 Volt Intelligent Thermostat (with 4.3" LCD Display)



## 24 Volt Intelligent Thermostat (With 4.3" LCD Display)

Mx-TS1



### Description:

The Bi-Directional, intelligent thermostat uses wireless communication to provide quick and easy implementation of energy saving HVAC controls. When the thermostat receives an "occupied" signal from a switch or sensor, the user immediately gains full control over the HVAC settings. When the thermostat receives an "unoccupied" signal, it sets the room back to the preset unoccupied temperature. It is designed for use with most basic gas/electric furnace/air conditioning units, PTHP/PTAC systems, 4-pipe, or 2-pipe fan coil systems.

### Dimensional Drawing:

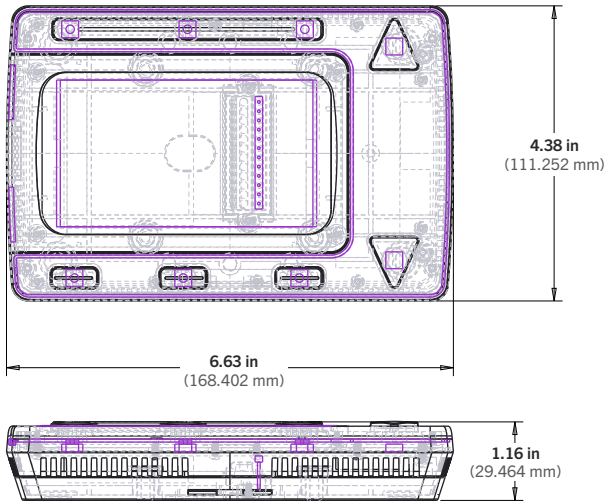

### Features Include:

- Compatible with key card switch, occupancy sensor, window/door sensor and other wireless transmitters.
- Controllable through smart phone as well as VenergyUI software
- Optional humidity sensor
- Optional manual controls
- Two way communication

### Equipment Needed for Installation:

- Phillips Screwdriver
- Electrical Tape
- Wire Nuts

# M9-TS1

24 Volt Intelligent Thermostat (with 4.3" LCD Display)



## Planning for Installation:

---

- Take a moment to prepare for installation and ensure optimal communications with other system components in the space
- Always utilize a qualified installer
- Create separation distance between interfering electronics such as fluorescent tube ends, ballasts, electronic transformers, and motors. Avoid mounting inside of metal enclosures.
- Obstructions of metal, concrete and dense building materials will reduce the range. Mount higher and away from obstructions to maximize range.

**WARNING:** To avoid risk of fire, shock, or death, TURN OFF POWER at circuit breaker or fuse and verify that it is OFF before installation begins. Make sure that it remains OFF until installation is complete.

**NOTE:** Read the WARNINGS AND CAUTIONS section before beginning these installation options. Read all steps for this option before taking any action to install the thermostat.

## Select ONE of the Following Thermostat Configurations:

---

### OPTION A: Heat Pump Configuration Installation

1. If retrofitting an old thermostat, remove the old device, carefully noting the wire connections on the old unit. Record wire color and terminal legends (Cable wire color for Control Feed, Load Feed, Common, Auxiliary Heat, Compressor, Low Fan, High Fan and Reversing Valve). Refer to Table A.
2. Install mounting bracket to the junction box with provided mounting screws.
3. Wire thermostat according to function as shown in Figure A.
4. Push wires into junction box. Rest bottom of thermostat on mounting tabs in mounting plate. Push top of thermostat towards wall and secure into place with self tapping screw.
5. Turn power on.

## Select ONE of the Following Thermostat Configurations (continued):

---

### OPTION B: 4-Pipe Fan Coil Configuration

1. Read all steps for this option before taking any action to install thermostat
2. If retrofitting old thermostat, remove old device, carefully noting the wire connections on the old unit. Record wire color and terminal legends (Cable wire color for Control Feed, Load Feed, Common Auxiliary Heat, Compressor, Low Fan, High Fan and Reversing Valve). Refer to Table A.
3. Install mounting bracket to the junction box with provided mounting screws.
4. Wire thermostat according to function as shown in Figure B. Note: If the mechanical system has only two fan speeds: Green-Low Fan, Violet-High Fan, Orange-Not Used.
5. Push wires into junction box. Rest bottom of thermostat on mounting tabs in mounting plate. Push top of thermostat towards wall and secure into place with self-tapping screw (included).
6. Turn power On.

### OPTION C: 2-Pipe Fan Coil Configuration

Note: Continuous fan is not available on 2-Pipe with Aquastat systems. Continuous fan is available on 2-Pipe with electric heat systems.

1. Follow instructions for a 4-Pipe installation but using Figure C for 2- Pipe Fan Coil with Aquastat or Figure D for 2 Pipe Fan Coil with Electric Heat.
2. Push wires into junction box. Rest bottom of thermostat on mounting tabs in mounting plate. Push top of thermostat towards wall and secure into place with self-tapping screw (included).
3. Turn power on.

# M9-TS1

24 Volt Intelligent Thermostat (with 4.3" LCD Display)



## Warnings & Cautions:

- HIGH VOLTAGE: A qualified installer or electrician must install this device. Follow all applicable electrical codes for installation.

## Connections & Correct Backplate Orientation:

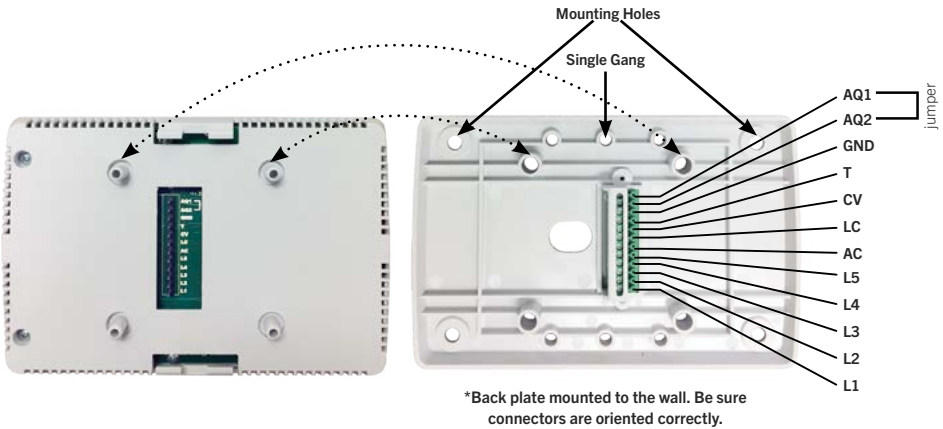

## Technical Specifications:

Part Numbers (Frequency Dependent)	M9-TS1 (902 MHz - North America) M8-TS1 (868 MHz - Europe and China) MJ-TS1 (928 MHz - Japan)
Range	50-150 feet (typical)
Input Voltage	24 V
Max Loads	24 V (1.5 amp / circuit)
Temperature Monitor Range	32°F to 99.9°F (0°C to 37.7°C)
Temperature Set Point Range	60°F to 85°F (15.5°C to 29.5°C)
Operating Temperatures	14°F to 131°F (-10°C to 55°C)
Storage Temperatures	-4°F to 131°F (-20°C to 55°C)
Sampling Rate	Every 5 seconds
Display format	Liquid Crystal Display (LCD)
Fan Control	Selectable: Auto Cycle, Low, Medium, High, Economy, Off
Memory	Stores up to 30 Switch IDs
Accuracy	+ / - 1°F (0.5°C)
Heat / Cool Control	1 heat and 1 cool circuit; Heat pump reversing valve circuit
Dimensions	4.38" (111.252 mm) x 6.63" (168.402 mm) x 1.16" (29.464 mm)
Radio Certifications	FCC (U.S. SZV-TCM2XXC) - IC (Canada 5713A-TCM2XXC)

# M9-TS1

24 Volt Intelligent Thermostat (with 4.3" LCD Display)



## Wiring Diagram:

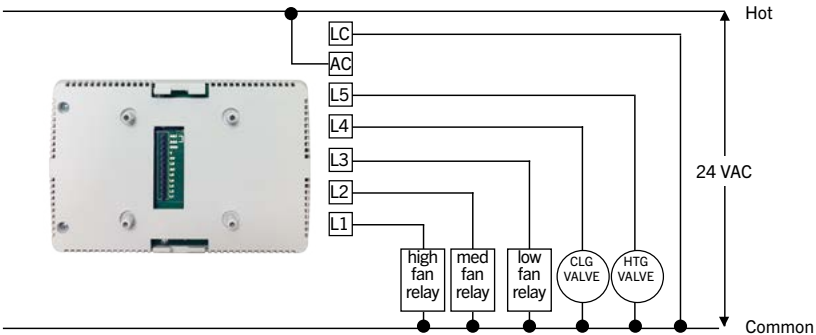

- AQ1: Aquastat Connection - AQ2
- AQ2: Aquastat Connection 2 - Jumper to AQ1
- GND: Common for 0-10 Volt Output and Thermistor Input
- T: Temperature Input - External Thermistor
- CV: Control Voltage Output - 0-10 Volts
- LC: Load Common, AC - COMM
- AC: Load Hot, AC - 24 VAC
- L5: Load 5 - Heat
- L4: Load 4 - Cool / Compressor
- L3: Load 3 - Low Fan Relay
- L2: Load 2 - Medium Fan Relay / Cool 2\*
- L1: Load 1 - High Fan Relay / Reverse Valve / Heat 2\*

\*Depending on Thermostat Configuration

## Conventional HVAC Systems:

Commonly Used Wiring Terminal Designators	Possible Wire Color	Possible Signal Names / Functions	Comments
C	Black	24VAC Common	From one side of the 24 VAC transformer, usually called the common side.
R or V	Red	24 VAC Hot	From the other side of the 24VAC transformer, usually called the hot side. The thermostat may connect this terminal with W (call for heat) or Y (call for cool), if RH and RC are not used / available. Some thermostats also use this supply to power themselves.
RH or 4	Red	24VAC hot usually used for call for heat	Functions as the source of power for the W terminal. Thermostat usually connects this terminal with W when it calls for heat.
RC	Red	24VAC hot usually used for call for cool	Functions as the source of power for the Y terminal. Thermostat usually connects this terminal with Y when it calls for heat.
G	Green	Activate blower fan	The fan switch on the thermostat usually connects this terminal with R when it is in the ON position.
W or W1 or W2	White	Call for heat	The thermostat usually connects this terminal with R or RG when it calls for heat. Thermostat usually connects this terminal with G when the fan switch is set to AUTO. Some thermostats require a jumper from W to Y if a heat pump is used. Other thermostats might use this as a second-stage heating. Sometimes W2 designates auxiliary heating in systems that use heat pumps.
Y	Yellow	Call for cool	The thermostat usually connects this terminal with R or RC when it calls for heat. The thermostat usually connects this terminal with G when the fan switch is set to AUTO. Could also be for cooling of the first-stage heating on a heat pump.
S1 and S2	Varies	Outside air temperature display	Used to display the outside air temperature on some digital thermostats.