

Wireless Receptacle Controller

M9-RECP-W/B



Available in White or Black

White = M9-RECP-W

Black = M9-RECP-B

Basic Operation

The Wireless Receptacle Outlet provides a simple solution to meet energy codes without requiring complex changes to a facility. The controller can retrofit your existing duplex receptacles simply and quickly, without the need for new wiring. The controller offers a duplex receptacle with a 15-amp relay- switched outlet and a 15-amp constant-power outlet. Its auxiliary output allows for additional standard outlets to be controlled by its internal relay. The Receptacle mounts in a standard electrical box and will accept a decorator style face plate (not included).

Arrow shaped LEDs provide permanent marking of the control outlet and users can choose to have the LEDs turned off.

The controller activates electrical loads with received input from a linked sensor or switch transmitting:

- Ambient light levels monitored by a wireless photo sensor
- Occupancy state monitored by a wireless occupancy sensor
- Switch action from a wireless single or dual paddle wall switch
- Switch action from a wireless key card switch
- Switch action from a wireless door/window switch
- Gateway control implementing schedules or other events

The Split Duplex Controller fits equally as well into hospitality applications. Responding to linked key card switches that monitor suite occupancy, control can be added to lighting or other electrical circuits to disable the loads when the suite is vacant. The controller can also be used to enable and disable air-conditioning equipment based on the occupancy state and/or patio door position.

Features

- Use for controlling plug-in electrical loads
- Occupancy based automation with auto-ON/ OFF or manual ON + auto-OFF using wireless occ sensors
- Monitors linked battery-free key card , proximity switches, wall switches, occupancy sensors, etc.
- Assign up to 20 battery-free wireless wall switches or sensors to one controller
- Radio reception range of 24 m (80 ft) - commercial office spaces (typical), up to 100m (330 ft) line of sight
- Low-cost alternative to running wires and conduit – ideal for retrofit projects
- Doubles as a telegram repeater
- Single-channel 15A relay and 15A constant- power outlets
- 120V power input
- ETL and cETL Listed
- Complies with FCC Part 15.231 and ICRSS-210
- Tamper resistant receptacles

Wireless Receptacle Controller

M9-RECP-W/B



Ordering Information

Wireless Receptacle Controller - White	M9-RECP-W
Wireless Receptacle Controller - Black	M9-RECP-B

Technical Specifications

Power Supply	120 VAC
Power Consumption	2.5 W max. full load
Outputs	N.O. Relay rating 15A@ 120 VAC, 2 x LEDs, Learn (green) and Power (red)
Inputs	LEARN and CLEAR buttons for sensor assignment
Maximum Load Ratings	15A @ 120 VAC
Radio Frequency	902 MHz
Antenna	Integrated whip
Transmission Range	24 m (80 ft) - commercial office spaces (typical), up to 100m (330 ft) line of sight
Operating Temperature	-10°C to 45°C (14°F to 113°F) ambient
Relative Humidity	5% to 95% rH (non-condensing)
Weight	118 g (4.2 oz)
Dimensions	41.0 x 70.3 x 42.5 mm (1.61 x 2.77 x 1.67") <i>NOTE: Wires exit from the rear of the ERNR. Allow for additional space when selecting an electrical box</i>
Certifications	FCC: Part 15.231, IC: RSS-210, ETL Listed Component, Conforms to UL Standard 508, Certified to CAN / CSA Std. C22.2 No. 14

Wiring Diagram

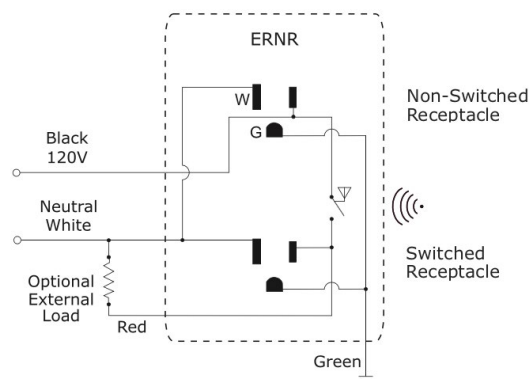

Dimensional Diagram

