



Proudly Made  
In America

# M9-OPUS-DRDLV

IN FIXTURE DALI NODE (POWERED BY 12-24 VAC / 12-36 VDC)

## OVERVIEW:

The Mx-OPUS-DRDLV provides bi directional, fixture level wireless DALI (digital addressable lighting interface) lighting control integration. Mx-OPUS-DRDLV receives incoming signals from wireless EnOcean devices and converts them into DALI commands, allowing for both occupancy based lighting control and daylight harvesting functionality. The Mx-OPUS-DRDLV can be paired with a variety of sensors and switches for stand alone operation, incorporation into a networked lighting system or integrated to BACnet utilizing the Mx-EBOX gateway.

## DESCRIPTION:

The Mx-OPUS-DRDLV is powered by 12-24 VAC / 12-36 VDC and includes a built in DALI Bus power supply of 10mA (per channel) at 12.7 VDC. The Mx-OPUS-DRDLV includes four individual, configurable and addressable channels. Each channel includes full range dimming, customizable scene control, building in dawn control, adjustable ramping speeds and adjustable rate of dimming.

## OPTIONS IN OPERATION:

**Local Control:** An on board microprocessor and memory allows for standardized operation at the driver level, eliminating the reliance on software or network configuration. Mx-OPUS-DRDLV can be utilized out of the box with default settings or configured for advanced operation through AirConfig software ([https://www.dropbox.com/s/mor2z812401nhti/airConfig\\_Setup.exe?dl=0](https://www.dropbox.com/s/mor2z812401nhti/airConfig_Setup.exe?dl=0)) by using the Magnum wireless USB dongle (Mx-USB). Preference and settings can be accomplished using simple drag and drop remote configuration in a localized fashion, even after the installation is complete.

**Software Driven:** The Mx-OPUS-DRDLV can also be used with Magnum's free Venergy software, allowing users to control lighting with their mobile devices.

**Integration to BAS:** The Mx-OPUS-DRDLV has the ability to communicate through Magnum's eBox (Mx-EBOX) and into an existing building automation system. The convergence of lighting and building automation allows for critical and now granular data to be communicated to the BAS for improved operational efficiency.



Proudly Made  
In America

# M9-OPUS-DRDLV

IN FIXTURE DALI NODE (POWERED BY 12-24 VAC / 12-36 VDC)

## FEATURES:

- DALI Compatible
- Built in DALI Bus Power Supply
- Energy reporting at fixture level (if driver is compatible)
- Powered 12-24 VAC / 12-36 VDC
- Mounts conveniently to driver
- Address up to 4 individual channels
- Connection for optional motion / lux sensor

## TECHNICAL DATA:

Part Numbers (Frequency Dependant)	M9 - 902 MHZ (standard for North America) M8 - 868 MHZ (Europe and China) MJ - 928 MHZ (Japan)
Input Voltage	12-24 VAC / 12-36 VDC
Input Sensors	Digital Passive Infrared Sensor 0-1020 Lux Sensor
Output	Built-in DALI Bus Power Supply of 10mA @ 12.7 VDC (10mA per channel)
Number of DALI Node Channels	4
Standby Power	< 1W
Operating Temperature	32° - 140°F (0° - 60°C) - Indoor use only
Wireless Protocol	EnOcean Wireless Protocol
EnOcean Profile	A5-38-08 central controller D2-29-06 status
Wireless Range	150 ft (50 ft-150 ft typical) / 45.72 m (15.24 m - 45.72 m)
Certifications	IEC 62386-101:2014 IEC 62386-103:2014 DLC UL Listed
Dimensions	Width: 1.30" (33.02 mm) Length: 3.09" (78.49 mm) Height: 0.89" (22.61 mm)



MAGNUM  
OPUS

-2-

\*Subject to change



Proudly Made In America

# M9-OPUS-DRDLV

IN FIXTURE DALI NODE (POWERED BY 12-24 VAC / 12-36 VDC)

## DIMENSIONS:

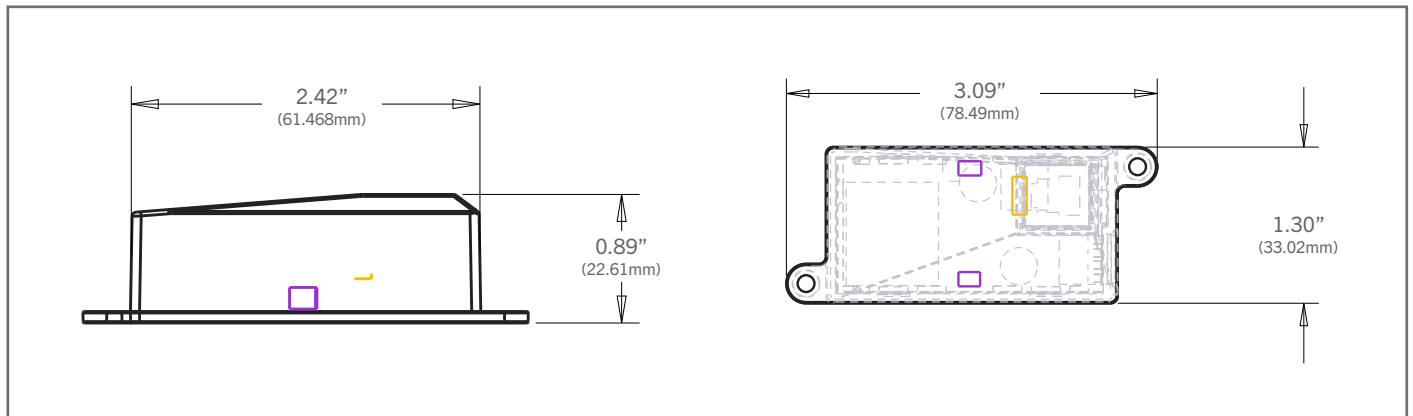

## WIRING DIAGRAM & ANTENNA NOTE:

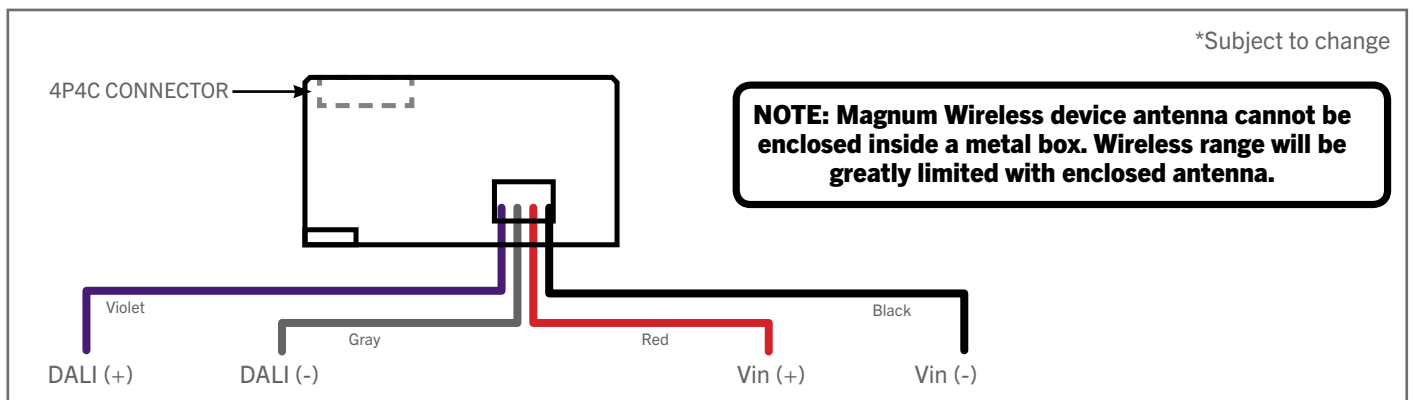



Proudly Made  
In America

# M9-OPUS-DRDLV

IN FIXTURE DALI NODE (POWERED BY 12-24 VAC / 12-36 VDC)

## OPTIONAL WIRED MOTION COMBINED LUX SENSOR:

This product has an optional motion combined LUX sensor that is connected to the controller via a simple 3-wire connector. The separate sensor is optional and is available for both high bay sensing (up to 39 feet) and for standard, low ceiling applications (up to 15 feet).

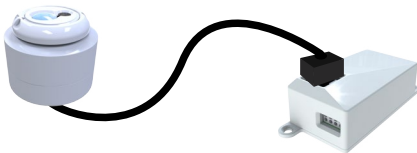

Mx-OPUS-LPML wired motion / lux sensor for low ceiling applications of up to 15 ft (4.572 m)

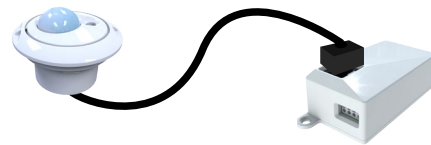

Mx-OPUS-HPML wired motion / lux sensor for high bay applications of up to 39 ft (11.887 m)