

Product Installation Guide



Automatic Load Control Relay M9-ALCR

OVERVIEW

The Magnum MX-ALCR is a UL 924 listed emergency lighting control device. This device is designed to ensure a “lights on state” during a power outage. The MX-ALCR senses when a power outage occurs and switches on the connected emergency lighting load to full brightness, bypassing any normal lighting switches and dimmer controls.

ELECTRICAL SPECIFICATIONS

Rated for indoor use only. UL, cUL listed Emergency Lighting and Power under UL 924 at line voltages of 120 and 277 VAC, 60 Hz.

- Load Rating of 10A Max at 277 VAC



WARNING: Risk of electric shock! The MX-ALCR utilizes high voltage and should only be installed by a qualified installer or electrician. Follow all local codes for installation and follow the proper lockout/tag out procedures per NFPA Standard 70E.

INSTALLATION

IMPORTANT SAFEGUARDS

When using electrical equipment, basic safety precautions should always be followed including the follow:

- READ AND FOLLOW ALL SAFETY INSTRUCTIONS.
- Do not use outdoors
- Install this unit to an approved electrical enclosure only. This emergency device must be installed in locations and at heights where it will not readily be subjected to tampering by unauthorized personnel.
- The use of accessory equipment not recommended by the manufacturer may cause an unsafe condition.
- Do not use this equipment for other than intended use.

SAVE THESE INSTRUCTIONS



WARNING: Before terminating the AC power wiring verify the breakers for the normal power and emergency power are in the off position and follow the proper lockout/tag out procedures per NFPA Standard 70E

1. Turn off all electrical power supplying this equipment before working on or inside the equipment, including the emergency lighting circuit. Always use a properly rated voltage sensing device to confirm that power is off.
2. Feed the MX-ALCR wiring through the preferred mounting box knockouts.
3. Attach the MX-ALCR to the exterior of the junction box or panel with the ½” threaded nipple.
4. Wire the MX-ALCR according to the wiring diagram in the wiring section; follow all applicable national and local electrical codes.

TESTING - FOR CONFIGURATION 2

1. Switch 1 light off using wireless switch (M9-ESRP or M9-ASW1)
2. Press Test Button and Keep Depressed – Light will turn on to full brightness
3. Release button – Light will shut off

MAINTENANCE

No maintenance is required to keep the MX-ALCR functional. However, regular testing should be performed.

WIRING

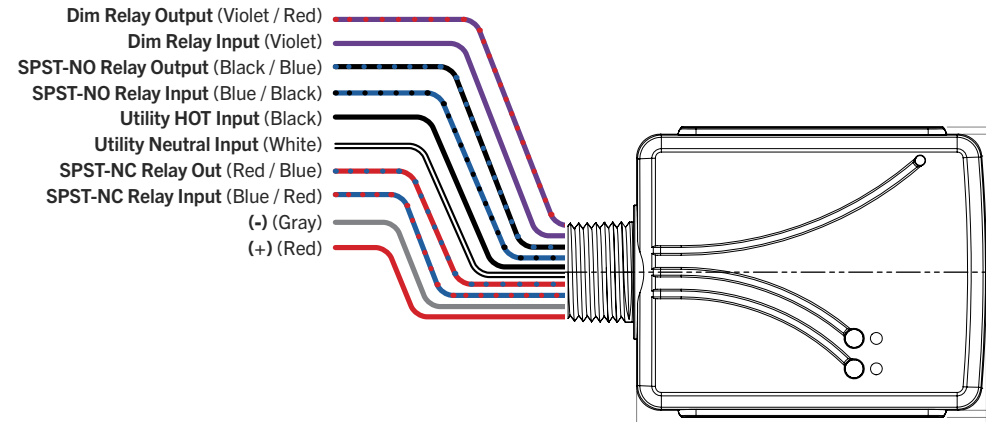

EXAMPLES OF USE

Configuration 1

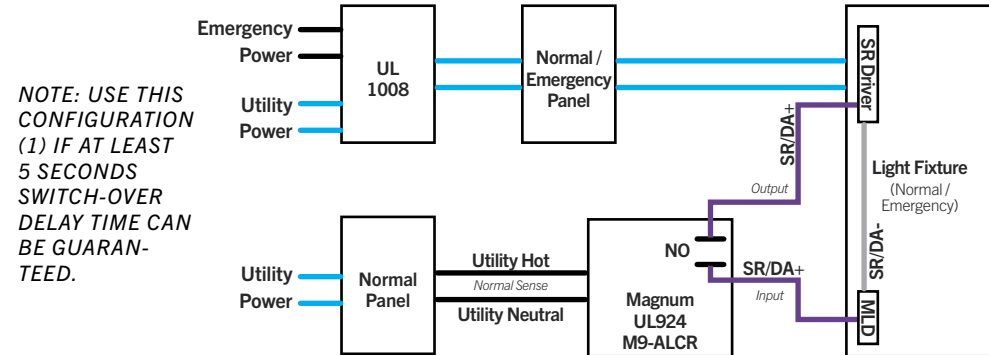

NOTE: USE THIS CONFIGURATION (1) IF AT LEAST 5 SECONDS SWITCH-OVER DELAY TIME CAN BE GUARANTEED.

Configuration 2

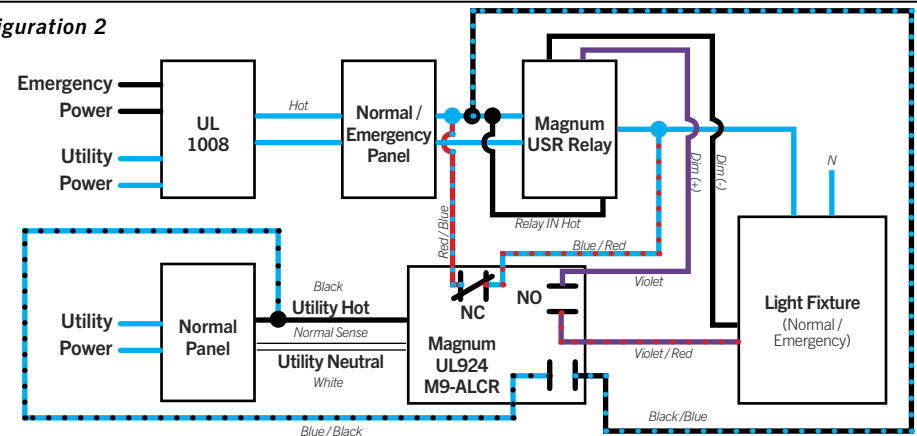

Product Installation Guide



Automatic Load Control Relay

Mx-ALCR

EXAMPLES OF USE (CONTINUED)

Configuration 3

NOTE: USE THIS CONFIGURATION (3) IF THERE IS NO SWITCH OVER DELAY TIME SUCH AS UPS SYSTEMS.

