



Proudly Made
In America

OPUS EVO mounted to fixture

Mx-OPUS-MLDE

FIXTURE INTEGRATED LIGHTING CONTROL

OVERVIEW:

Magnum's fixture integrated Mx-OPUS-MLDE node, when connected to the Philips Advance Xitanium SR LED driver, enables any lighting manufacturer to deliver simple, fully connected fixtures. The small and sleek form factor includes a digital PIR and ambient light sensing for daylight harvesting applications as well as occupancy detection. Easy to integrate at the fixture level, OPUS node bi-directionally communicates data to and from the lighting control network. This even includes accessing and reporting valuable information about power consumption of individual fixtures.

DESCRIPTION:

The Mx-OPUS-MLDE is designed to fit into the Philips EvoKit LED Retrofit design for both 2'x2' and 2'x4' troffers. The slanted troffer in the EvoKit LED includes a knockout that allows the Mx-OPUS-MLDE to clip in with ease. Although configurable for advanced settings, the Mx-OPUS-MLDE is designed for plug and play applications. The Mx-OPUS-MLDE is flexible enough for both localized control as well as software driven functionality and also integration to BACnet through Magnum's eBox (Mx-EBOX).

OPTIONS IN OPERATION:

Local Control: An on board microprocessor and memory allows for standardized operation at the fixture level, eliminating the reliance on software or network configuration. Mx-OPUS-MLDE can be utilized out of the box with default settings, manually paired to sensors and switches or configured for advanced operation through AirConfig (download.magnum-innovations.net). Even advanced schedules, preferences and behavior settings can be accomplished using simple drag and drop remote configuration in a localized fashion, even after installation is completed.

Software Driven: The Mx-OPUS-MLDE can also be used with Magnum's VenergyUI software, allowing users to utilize their mobile devices to connect to the lighting network and control fixtures remotely. VenergyUI includes macros, scheduling, demand response and real time energy reporting of each fixture.

Integration to BAS: The Mx-OPUS-MLDE has the ability to communicate information through Magnum's eBox (Mx-EBOX) and into an existing building automation system. When driven by the Philips Advance Xitanium SR LED driver, the driver provides energy reporting data directly to the sensor unit. This data can then be communicated to the Mx-eBox and visualized in the BAS. The convergence of lighting and building automation allows for granular information to be communicated to the BAS for improved operational efficiency.

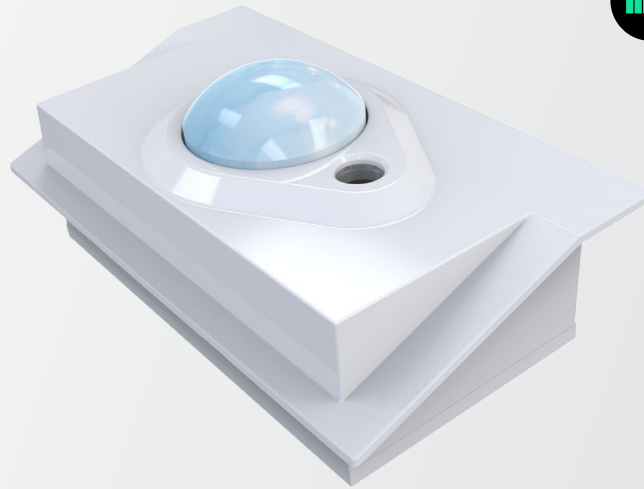

Proudly Made
In America

OPUS EVO mounted to fixture

Mx-OPUS-MLDE

FIXTURE INTEGRATED LIGHTING CONTROL

FEATURES:

- Full digital passive infrared
- Light Level
- Wireless communication
- Daylight harvesting
- Zone control allows multiple fixtures to share data
- Powered from driver
- Energy reporting at fixture level
- Remotely configurable

TECHNICAL DATA:

Part Numbers (Frequency Dependant)	M9-OPUS-MLDE (902 MHz - North America) M8-OPUS-MLDE (868 MHz - Europe & China) MJ-OPUS-MLDE (928MHz - Japan)
Motion Sensing	Digital Passive IR
Detection Distance	12 m (39.3696 ft)
Detection Range (Horizontal x Vertical)	102° x 92°
Detection Zone	92 Zones
Ambient Light Sensing	0-94.8 FC (0-1020 LUX) Photo IC type
Operating Temperature	32° - 140°F (0° - 60°C) - Indoor use only
Minimum Power Requirement	16V @24mA from Xitanium SR driver or DALI driver
Standby Power	< 1W
Enclosure	ABS Plastic
Radio Frequency	868 MHz, 902 MHz, 928 MHz
EnOcean Profile	A5-38-08 central controller D2-29-06 status
Wireless Range	150 ft (50 ft to 150 ft typical)
Certifications	IEC 62386-101:2014 IEC 62386-103:2014
Dimensions	W: 2.34" (59.44 mm) x H: 0.59" (14.99 mm) D: 1.26" (32 mm)





Proudly Made
In America

OPUS EVO mounted to fixture

Mx-OPUS-MLDE

FIXTURE INTEGRATED LIGHTING CONTROL

DETECTION PERFORMANCE:

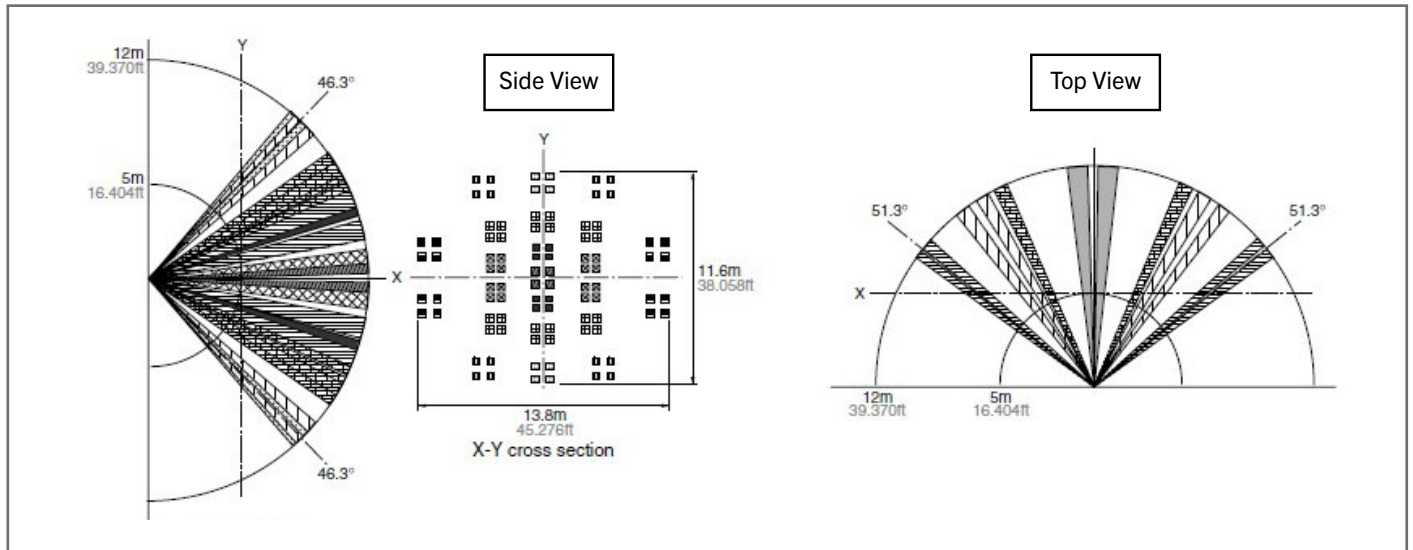

DIMENSIONS:

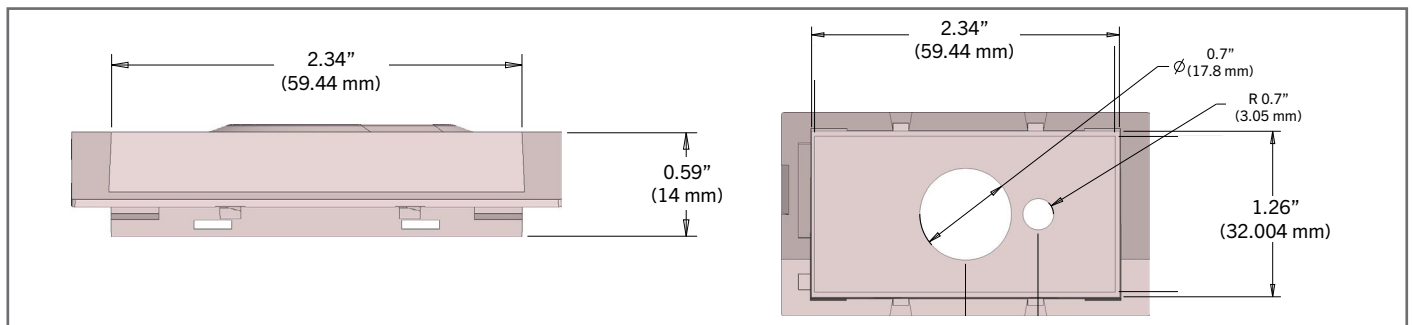

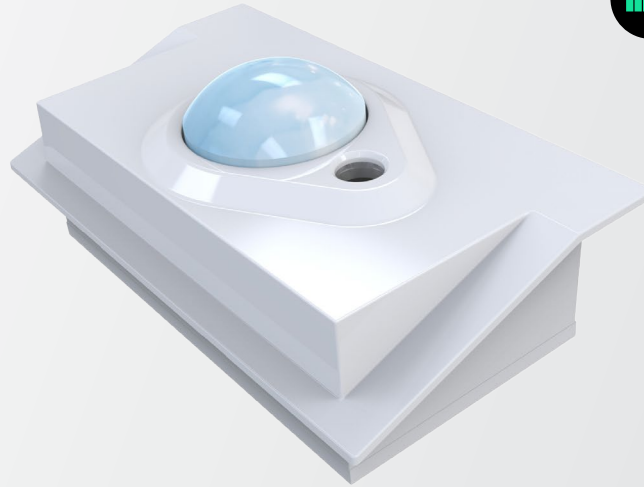

Proudly Made
In America

OPUS EVO mounted to fixture

Mx-OPUS-MLDE

FIXTURE INTEGRATED LIGHTING CONTROL

WIRING DIAGRAM & ANTENNA NOTE:

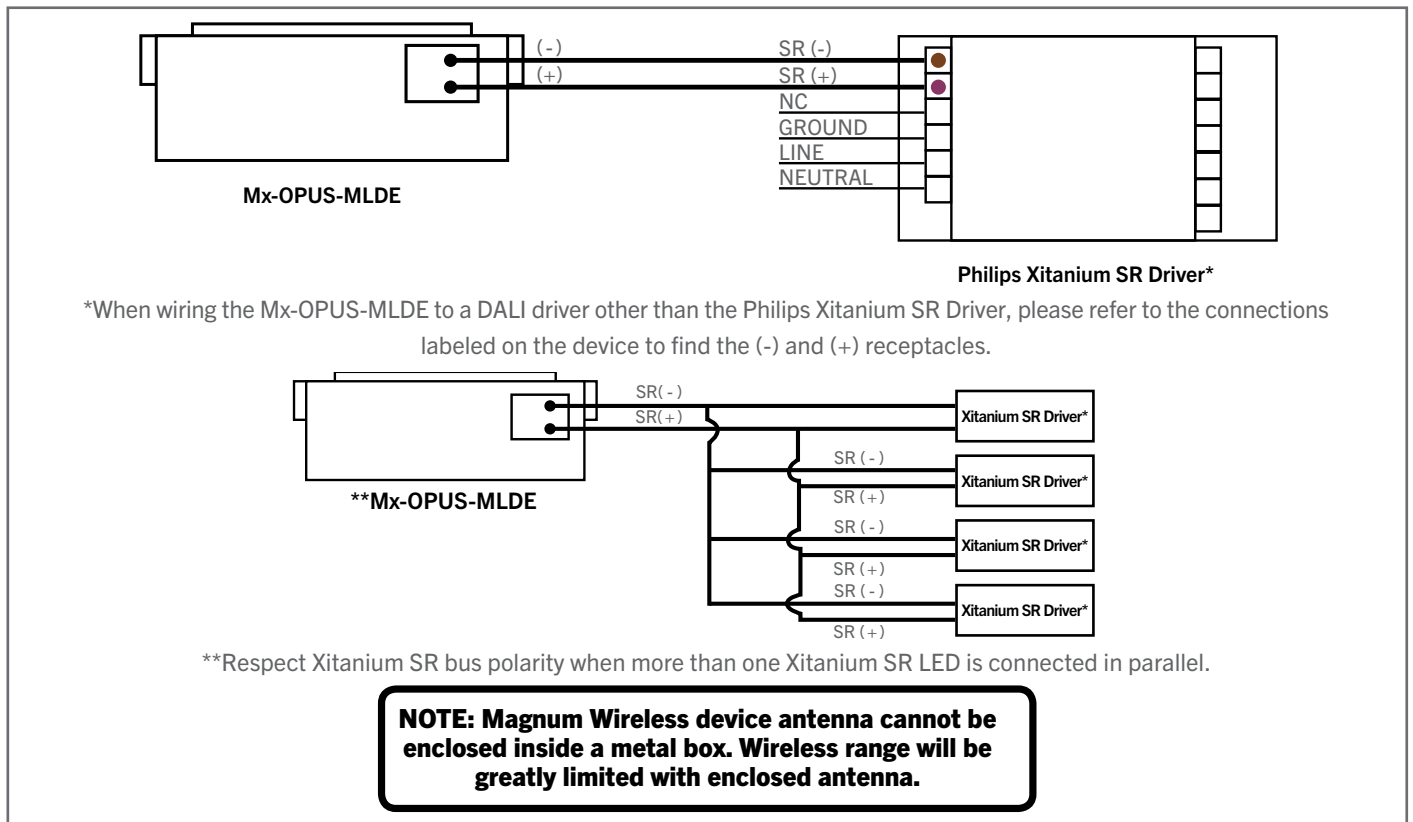

ENVIRONMENTAL CONCERNS:

- Humidity degree: 15 to 85%Rh (Avoid condensation or freezing of this product)
- Pressure: 86 to 106KPa
- Overheating, oscillations, shocks can cause the sensor to malfunction.
- This sensor is not waterproof or dust-proof. Avoid use in environments subject to excessive moisture, condensation, frost, containing salt air or dust.
- Avoid use in environments with corrosive gases.